

All Dimensions are in MM

Rev.No.	Ch.Let	Alterations	Date	Sign.	Appd.

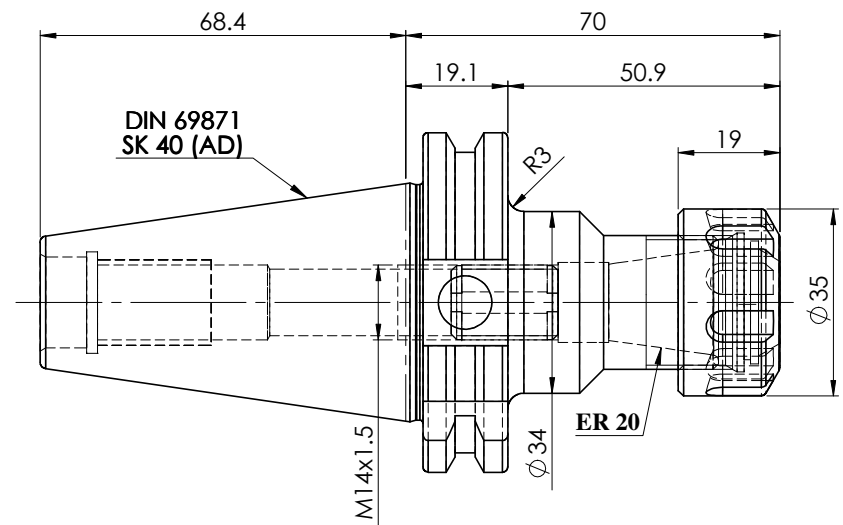
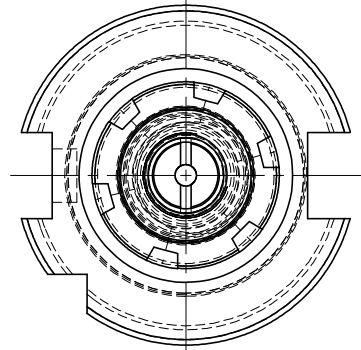

LABEL:

2002261.0400
SPANNZANGENFUTTER
ER COLLET CHUCK HOLDER
ISO 7388 - 1 (DIN69871) SK40 AD
ER20 x 070 mm
G6.3 / 15000 U/MIN

MARKING : ISO 7388 - 1 (DIN 69871) SK40 AD CCH ER20 H070
G6.3 15000 U/MIN

NOTE:

BALANCING 6.3G @ 15000 RPM

WEIGHT : 1.0 Kg

ITEM NO.	PART NUMBER	DESCRIPTION	QTY.
1	FWS401A-ERS20070	SK40CCHER20070WW	1
2	NUTER20	COLLET NUT	1
3	FTSCWM14X1.5	STOPPER SCREW	1

μm	0.012	0.025	0.05	0.1	0.2	0.4	0.8	1.6	3.2	6.3	12.5	25	50
GRADES	N1	N2	N3	N4	N5	N6	N7	N8	N9	N10	N11	N12	
SYMBOLS	▽▽▽			▽▽▽			▽▽			▽			~
TOLERANCE FREE DIMENSIONS TOLERANCE	Dimns.		Dia	Length	MATERIALS:		2022	NAME	DATE	WEMAG 2002261.0400			
	0.5 to 3	± 0.05	± 0.10	16MnCr5		DRAWN	SVR	01/07					
	3 to 6	± 0.10	± 0.15			CHECKED	RVL	01/07					
	6 to 30	± 0.15	± 0.20			APPROVED							
	30 to 120	± 0.20	± 0.25	PART NAME:		SCALE : NTS		QTY. :	DRAWING No.				
	120 to 500	± 0.30	± 0.50	SK40CCHER20070WW					FWS401A-ERS20070				

REV. 00