

## Plan-Aufsteckfräser, 45°

Ø D mm	Z	Ø d H7 mm	L mm	Ø D1 mm	a <sub>p</sub> max. mm	Wendeschneidplatte	format	
							2999 €	Bestell- Nr.
40	3	16	40	53	6,5	SEET/SEKT 1204...	179,50	...2050
50	4	22	48	65	6,5	SEET/SEKT 1204...	199,50	...2055
63	5	22	48	78	6,5	SEET/SEKT 1204...	225,00	...2060
80	6	27	50	95	6,5	SEET/SEKT 1204...	248,50	...2065
100	6	32	50	115	6,5	SEET/SEKT 1204...	290,50	...2070
125	7	40	63	140	6,5	SEET/SEKT 1204...	356,00	...2075
160	8	40	63	173	6,5	SEET/SEKT 1204...	696,50	...2080

(W280)



format  
professional quality

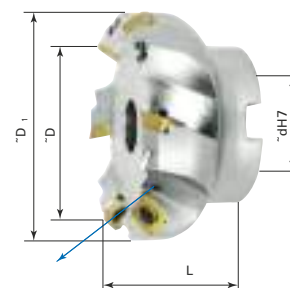

Lieferung  
ohne  
Wendeschneid-  
platten.

## Ersatzteil

Ausführung	VE	format	
		2999 €	Bestell- Nr.
Schraube	5 Δ	5,85	...0193

(W281)

Δ Abgabe nur als ganze Verpackungseinheit möglich.



Schraube

## ISO-Wendeschneidplatte



SEKT ALU

SEET AFSN

format  
professional quality

ISO-Bezeichnung	Schneidstoffsorte	Schnittgeschw. Vorschub Schnitttiefe	P Stahl	M Rostfrei	K Guss	N Alu	S Superleg.	H Hart	VE	format	
										2999 €	Bestell- Nr.
SEKT 1204	ALU 	v <sub>c</sub> m/min f <sub>z</sub> mm a <sub>p</sub> mm	-	-	-	250-1000 0,12-0,4 0,2-7	-	-	10 Δ	12,80	...5176
SEET 1204AFSN	UNI 	v <sub>c</sub> m/min f <sub>z</sub> mm a <sub>p</sub> mm	255-370 0,20-0,40 1,0-6,5	150-220 0,20-0,30 1,0-4,9	-	-	50-110 0,20-0,24 1,0-3,9	-	10 Δ	17,65	...5170
SEET 1204AFSN	INOX 	v <sub>c</sub> m/min f <sub>z</sub> mm a <sub>p</sub> mm	165-265 0,20-0,30 1,0-6,5	95-155 0,20-0,23 1,0-4,9	190-280 0,2-0,4 0,5-6,0	-	-	-	10 Δ	17,65	...5173

(W282)

Δ Abgabe nur als ganze Verpackungseinheit möglich.

## Planfräser, 45° (Schraubenklemmung)

Ø D mm	Z	Ø d H7 mm	Ø d1 mm	L mm	Ø D1 mm	a <sub>p</sub> max. mm	Wendeschneidplatte	format	
								2999 €	Bestell- Nr.
50	4	22	63	50	18	6,5	SEKN/SEER 1203...	370,50	...0300
63	5	22	76	50	18	6,5	SEKN/SEER 1203...	435,00	...0305
80	6	27	93	50	38	6,5	SEKN/SEER 1203...	467,00	...0310

(W280)



format  
professional quality

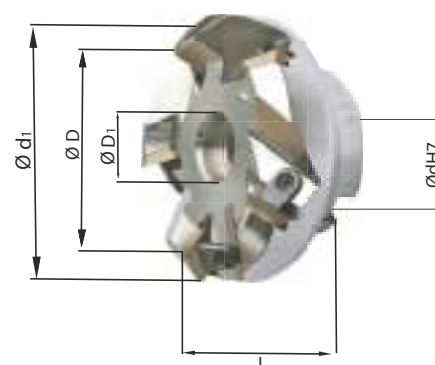

Lieferung ohne Wendeschneidplatten.

## Ersatzteil

Ausführung	format		Bestell- Nr.
	5840 €	5886 €	
Winkelschraubendreher, sechskant, 4 mm	0,39	-	...0040
Schraubendreher, T9 x 60 mm	-	6,70	...0035
Schraubendreher, T15 x 80 mm	-	6,90	...0050

(W528) (W543)

Winkelschraubend-  
dreher

Schraubendreher