

Schaftfräser

Ausführung: Mit Zentrumschnitt, zum Bohren geeignet.

Anwendung: Einsetzbar zum Fräsen von Keil- und Passfedernuten P9 sowie für die universelle Bearbeitung.

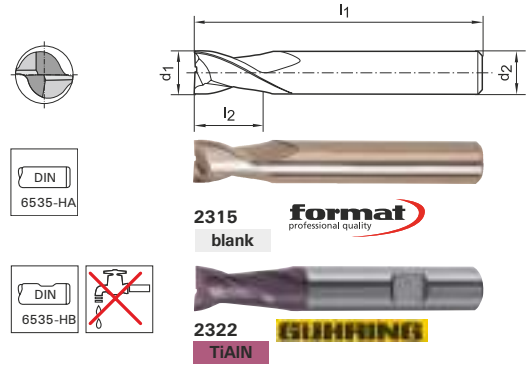
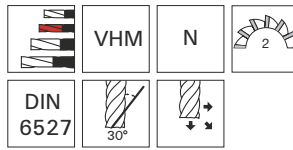

Einsatz	STAHL			INOX			GUSS		SOND.-LEG.	NE-METALLE				GEHÄRTETER STAHL			Bestell-Nr.
	< 700 N/mm ²	< 1000 N/mm ²	< 1400 N/mm ²	ferrit./martens.	austenitisch	Duplex	GG/GTS	GGG	Titan > 850 N/mm ²	Alu < 8% Si	Alu > 8% Si	Kupfer/Kupfer-Leg.	Graphit/GFK/CFK/Duropl.	< 55 HRC	< 60 HRC	> 60 HRC	
V _c [m/min]	60	60	-	-	-	-	70	56	25	90	-	50	-	-	-	-	2315
	115	92	74	50	40	32	120	96	40	150	120	80	-	30	-	-	2322

Ø d ₁ = h10 mm	Schneidenlänge l ₂ mm	Gesamtlänge l ₁ mm	Schaft-Ø d ₂ = h6 mm	f _z mm	format		Bestell-Nr.
					STAHL < 1000 N/mm ²	GEHÄRTET 2315 blank / 2322 TiAlN	
2	3	50	6	0,005	€ 14,95	€ 25,00	...0200
3	4	50	6	0,01	€ 13,25	€ 24,40	...0300
4	5	54	6	0,02	€ 12,40	€ 23,20	...0400
5	6	54	6	0,02	€ 12,40	€ 23,20	...0500
6	7	54	6	0,024	€ 12,30	€ 22,70	...0600
8	9	58	8	0,032	€ 14,60	€ 30,10	...0800
10	11	66	10	0,038	€ 24,20	€ 44,40	...1000
12	12	73	12	0,046	€ 34,80	€ 62,00	...1200
14	14	75	14	0,054	€ 47,80	€ 87,60	...1400
16	16	82	16	0,054	€ 57,80	€ 102,50	...1600
18	18	84	18	0,066	€ 83,70	€ 151,50	...1800
20	20	92	20	0,066	€ 97,90	€ 161,50	...2000

Schaftfräser

Ausführung: Mit Zentrumschnitt, zum Bohren geeignet.

Anwendung: Einsetzbar zum Fräsen von Keil- und Passfedernuten sowie für die universelle Bearbeitung.

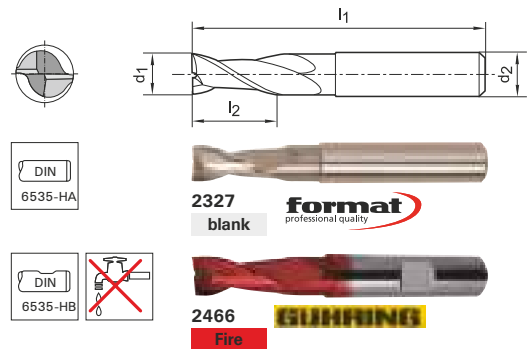
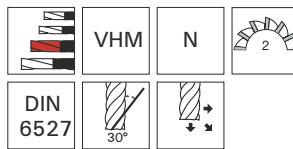

Einsatz	STAHL			INOX			GUSS		SOND.-LEG.	NE-METALLE				GEHÄRTETER STAHL			Bestell-Nr.
	< 700 N/mm ²	< 1000 N/mm ²	< 1400 N/mm ²	ferrit./martens.	austenitisch	Duplex	GG/GTS	GGG	Titan > 850 N/mm ²	Alu < 8% Si	Alu > 8% Si	Kupfer/Kupfer-Leg.	Graphit/GFK/CFK/Duropl.	< 55 HRC	< 60 HRC	> 60 HRC	
V _c [m/min]	60	60	30	-	-	-	70	56	25	90	-	50	-	-	-	-	2327
	115	92	74	50	40	32	120	96	40	150	120	80	-	30	-	-	2466

Ø d ₁ = h10 mm	Schneidenlänge l ₂ mm	Gesamtlänge l ₁ mm	Schaft-Ø d ₂ = h6 mm	f _z mm	format		Bestell-Nr.
					STAHL < 1000 N/mm ²	GEHÄRTET 2327 blank / 2466 Fire	
2	6	57	6	0,005	€ 19,35	€ 27,80	...0200
2,5	7	57	6	0,005	€ 19,35	-	...0250
2,8	7	57	6	0,01	€ 19,35	-	...0280
3	7	57	6	0,01	€ 17,10	€ 27,80	...0300
3,8	8	57	6	0,02	€ 19,10	-	...0380

Fortsetzung nächste Seite