

1.8

Schruppfräser

Ausführung: Mit Zentrumschnitt, zum Bohren geeignet.

Anwendung: Einsetzbar zum Umfangs- und Stirnfräsen.

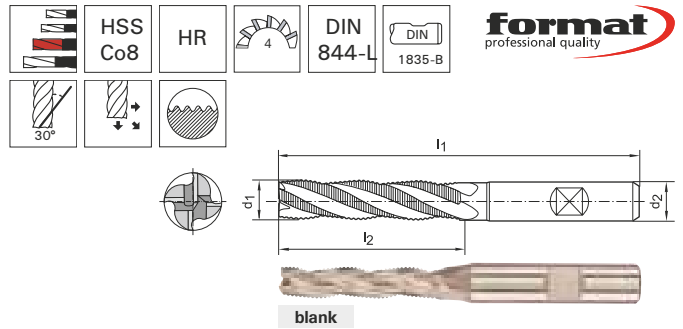

Einsatz	STAHL			INOX			GUSS		SOND.-LEG.	NE-METALLE			GEHÄRTETER STAHL			Bestell-Nr.	
	< 700 N/mm ²	< 1000 N/mm ²	< 1400 N/mm ²	ferrit./martens.	austenitisch	Duplex	GG/GTS	GGG	Titan > 850 N/mm ²	Alu < 8% Si	Alu > 8% Si	Kupfer/Kupfer-Leg.	Graphit/GFK/CFK/Duropl.	< 55 HRC	< 60 HRC		> 60 HRC
V _c [m/min]	25	25	-	16	14	-	21	23	-	-	-	25	-	-	-	-	2226

Ø d ₁ = k12 mm	Schneidenlänge l ₂ mm	Gesamtlänge l ₁ mm	Schaft-Ø d ₂ = h6 mm	format		Bestell-Nr.
				STAHL < 1000 N/mm ²	2226 blank	
6	24	68	6	f _z mm	€	...0600
8	38	88	10	0,013	25,70	...0800
10	45	95	10	0,021	27,80	...1000
12	53	110	12	0,033	27,80	...1200
16	63	123	16	0,044	32,20	...1600
18	63	123	16	0,063	47,10	...1800
20	75	141	20	0,07	53,50	...1800
				0,08	59,10	...2000

(W206)

Schlitzfräser

Ausführung: Kreuzverzahnt.

Anwendung: Einsetzbar zum Fräsen von Scheibenfedernuten oder von Schlitten. Kein Verkleben durch Freischliff des Fräasers.

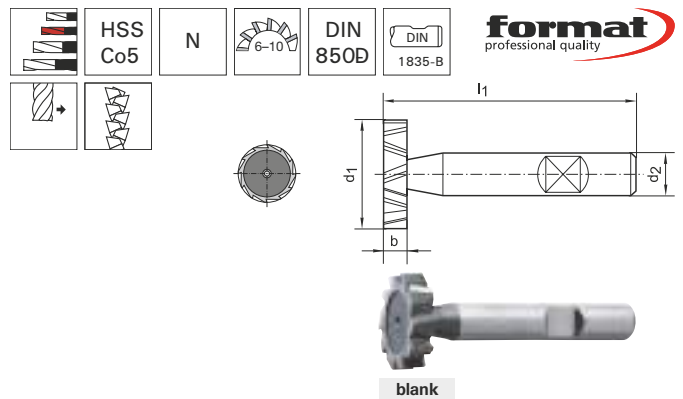

Einsatz	STAHL			INOX			GUSS		SOND.-LEG.	NE-METALLE			GEHÄRTETER STAHL			Bestell-Nr.	
	< 700 N/mm ²	< 1000 N/mm ²	< 1400 N/mm ²	ferrit./martens.	austenitisch	Duplex	GG/GTS	GGG	Titan > 850 N/mm ²	Alu < 8% Si	Alu > 8% Si	Kupfer/Kupfer-Leg.	Graphit/GFK/CFK/Duropl.	< 55 HRC	< 60 HRC		> 60 HRC
V _c [m/min]	20	15	10	15	12	-	25	30	-	-	48	28	-	-	-	-	2250

Ø x Breite d ₁ = h12 x b = e8 mm	für Scheibenfedern mm	Gesamtlänge l ₁ mm	Schaft-Ø d ₂ = h6 mm	format		Bestell-Nr.
				STAHL < 1400 N/mm ²	2250 blank	
13,5 x 2	2 x 5	56	10	f _z mm	€	...0001
13,5 x 3	3 x 5	56	10	0,007	26,30	...0007
13,5 x 4	4 x 5	56	10	0,007	26,30	...0010
16,5 x 3	3 x 6,5	56	10	0,007	26,30	...0016
16,5 x 4	4 x 6,5	56	10	0,017	28,90	...0019
16,5 x 5	5 x 6,5	56	10	0,017	28,90	...0022
19,5 x 3	3 x 7,5	63	10	0,023	36,90	...0025
19,5 x 4	4 x 7,5	63	10	0,023	36,90	...0028
19,5 x 5	5 x 7,5	63	10	0,023	36,90	...0031
19,5 x 6	6 x 7,5	63	10	0,023	36,90	...0032
22,5 x 4	4 x 9	63	10	0,033	39,20	...0034

(W204)

Fortsetzung nächste Seite